

CHALLENGER α ALPHA

ROTARY TILLER

- Challenger alpha rotary tiller offers best in class pulverization & hence optimum seed germination.
- Best fuel savings in its category.
- Equipped with heavy duty multispeed gear box for wider range of rotor speeds.
- Ensures excellent cutting and mixing of crop residue.

BOSS
OF TILLAGE



World's only rotary tiller with robust dual tubular & angular support for eliminating mechanical vibrations to almost zero.



WORLD'S NO. 1
HEAVY DUTY RANGE

www.sonalika.com

FOR ANY QUERY GIVE A MISSED CALL
869 639 2610

#T&C apply

WALK AROUND CHALLENGER ALPHA



Du cone mechanical oil seals ideal for dry & wet land operation.



Available with L&J type boron steel blades.

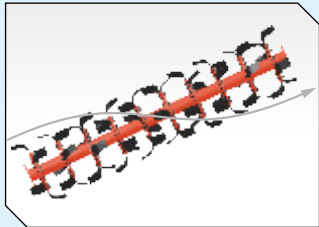

Helical arrangement of blades ensures less load on tractor & lesser fuel consumption.

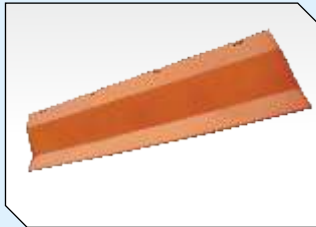

Heavy duty trailing board.



Robust structure for heavy vibration free field operation.



Oil immersed side bearing.

AVAILABLE IN SINGLE & MULTISPEED

A		B		ALPHA	SIDE GEAR
13	22	13	22	20 - 540 r.p.m.	Pinion 13 Crown 23 1000 r.p.m.
15	20	16	19	163	238
16	19	17	18	183	---
17	18	18	17	206	---
18	17	19	16	231	---
19	16	20	15	259	---
20	15			291	---

Boron Steel Blades

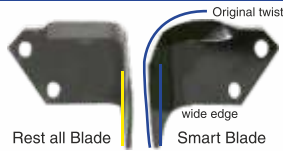

- 20% longer life.
- Hard to break & bend.
- Saves money & time.

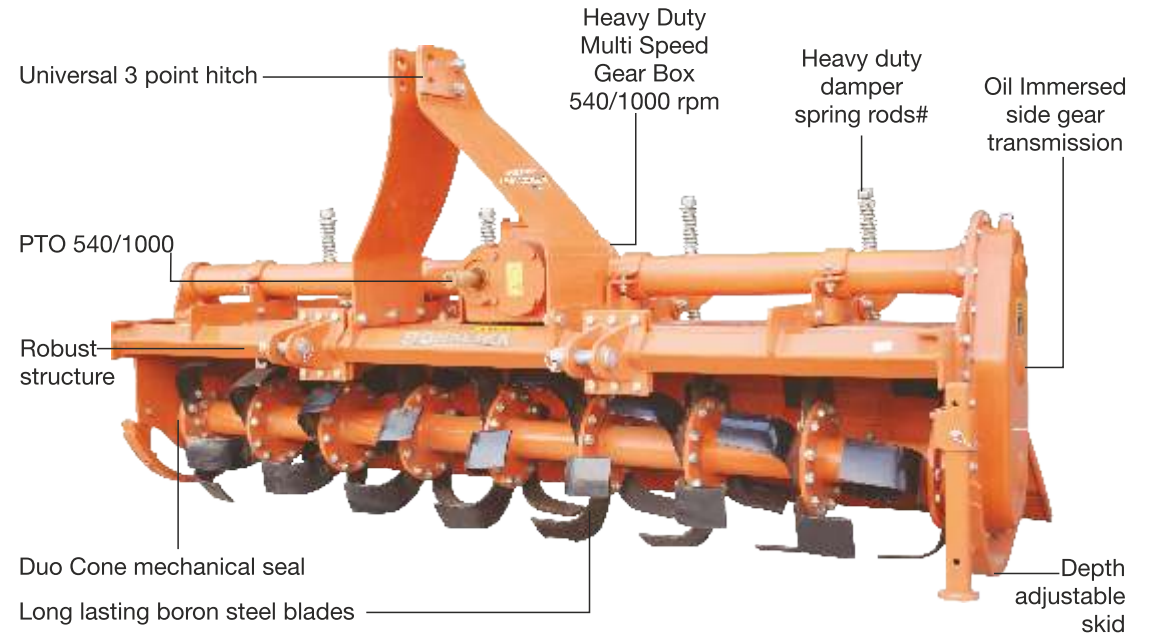

TECHNICAL DATA

Model (in feet)	Work Width		Total Width		Height cm	Weight in Kg. Approx.	PTO Speed RPM	No. of Blades	Type of Blade	HP
	Inch	cm	Inch	cm						
5	59	149	70	179	44/112	430	540/1000	36	L&J	45-50
5.5	71	180	77	194	44/112	445	540/1000	36	L&J	50-55
6	74	188	80	204	44/112	460	540/1000	42	L&J	50-55
7	79	200	90	230	44/112	490	540/1000	48	L&J	55-60
8	87	220	98	250	44/112	536	540/1000	54	L&J	60-65
9	106	271	118	301	44/112	570	540/1000	60	L&J	70-75
10	115	293	127	323	44/112	640	540/1000	66	L&J	75-90

4 no. of damper spring for 7 feet & above variants.

*The Product & Specifications are subject to change/discontinue without any notice on the sole discretion of manufacturer.

WORLD'S NO. 1

HEAVY DUTY RANGE

SONALIKA INDUSTRIES

(A UNIT OF INTERNATIONAL CARS & MOTORS LTD.)

Works & Admin Office: Vill. Chak Gujran, Jalandhar Road, Hoshiarpur -146 022 (Pb.), India
Tel.: +91 99149-34522, +91 1882-501320, Email: info@sonalikaindustries.com

Authorised Dealer

R0039094AA